

➤ **NEW**  
Improved float  
free bracket!



- Innovative and improved design

## FB-6 Float free bracket



[www.jotron.com](http://www.jotron.com)



## ► FB-6 Float free bracket

### Features:

- Innovative and improved design
- Internal improved "tilt-angle" for optimized EPIRB stability
- Same footprints/mounting as FB-4, FBH-4 and FB-5
- Simple to Install and Maintain

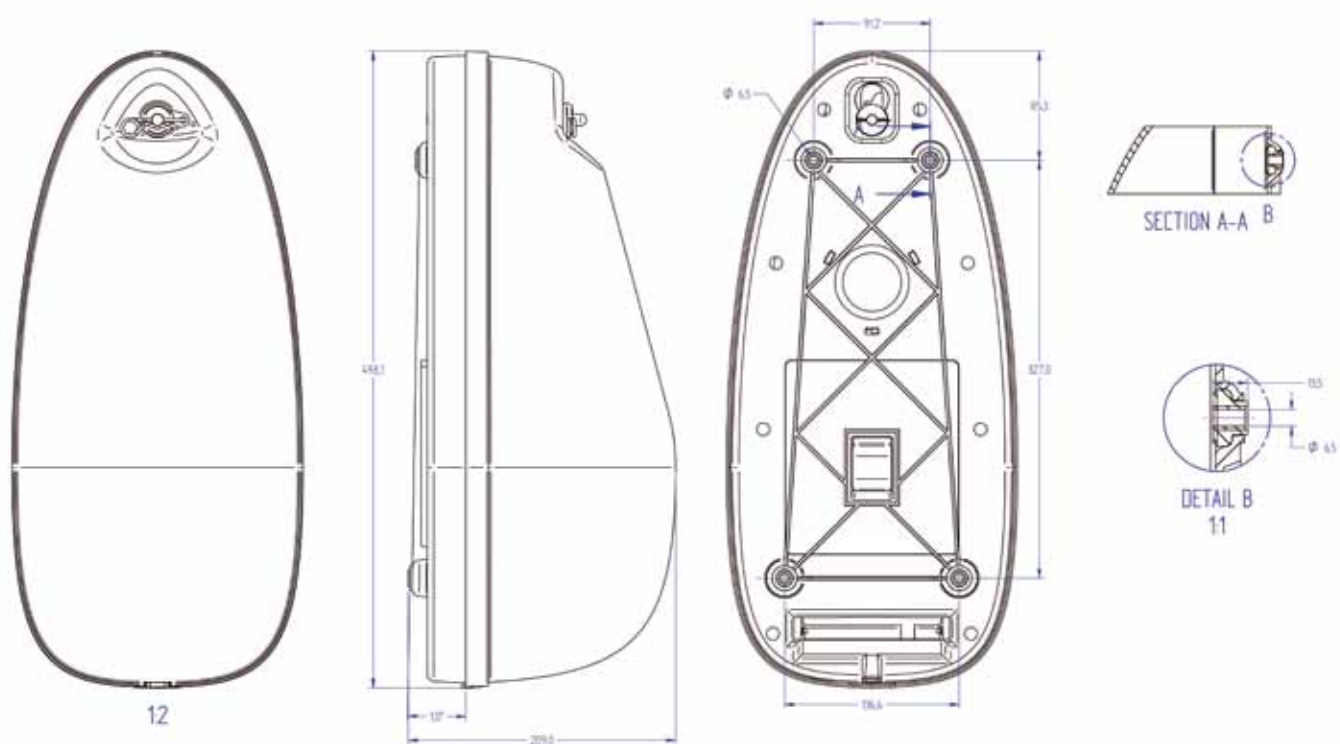

### Agent/Distributor:

Jotron AS reserves the right to change the design and/or specifications at any time without prior notice. Reservations are also taken towards any general errors that may occur.

[www.jotron.com](http://www.jotron.com)

## CONTACT INFORMATION

**Jotron AS**  
P.O.Box 54  
3281 Tjodalving  
Norway  
Tel: +47 33 13 97 00  
Fax: +47 33 12 67 80  
sales@jotron.com

**Jotron UK Ltd.**  
Crosland Park,  
Cramlington  
NE23 1LA,  
United Kingdom  
Tel: +44 (0) 1670 712000  
Fax: +44 (0) 1670 590265  
sales@jotron.co.uk

**Jotron Asia Pte. Ltd.**  
19 Loyang Way,  
Changi Logistics Centre  
Rear Office Block 04-26  
Singapore 508724  
Tel: +65 65426350  
Fax: +65 65429415  
sales-asia@jotron-asia.com

**Jotron USA, Inc.**  
10645 Richmond Avenue, Suite 140  
Houston, TX 77042  
USA  
Tel: +1 713 268 1061  
Fax: +1 713 268 1062  
contact.us@jotron-usa.com